

## Lader-Hülsenzähne

gesenkgeschmiedet aus hochverschleissfestem Stahl, gehärtet auf ca. 500 Brinell.

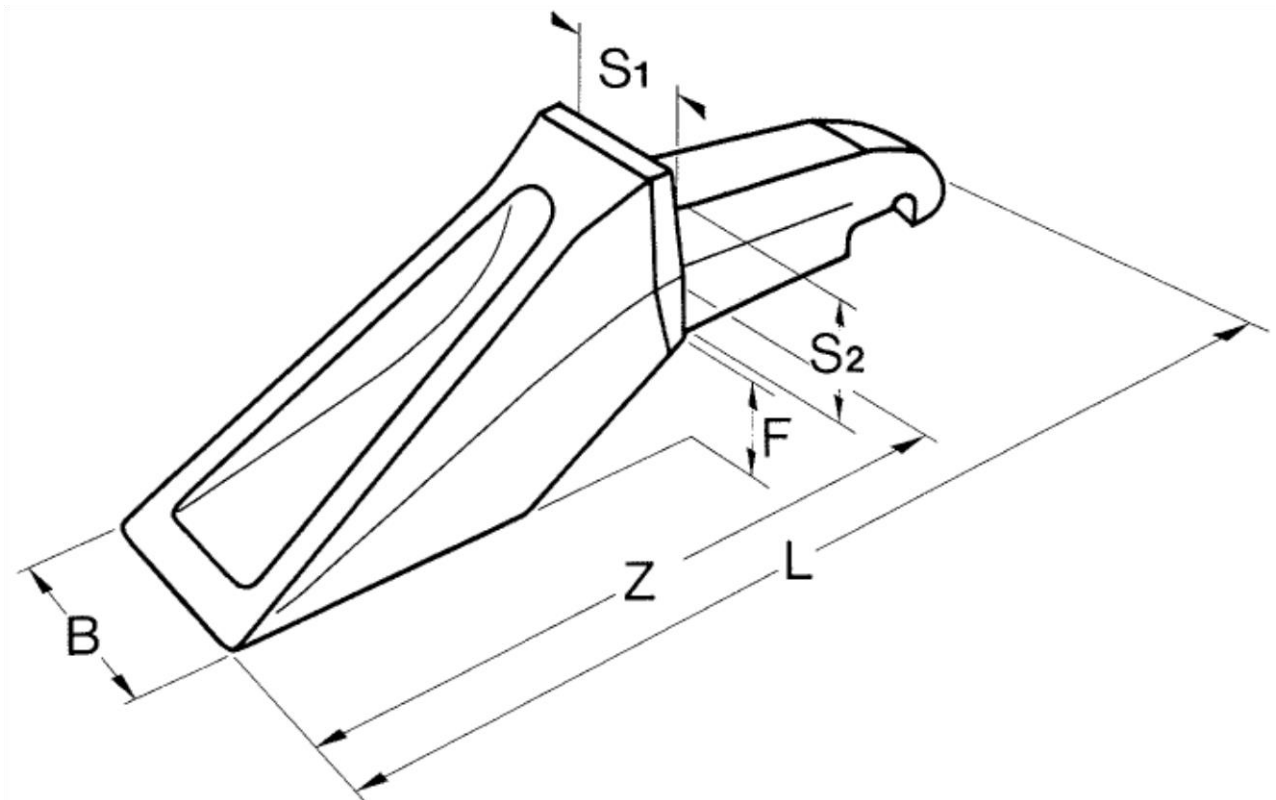

Bestell Nr.	Gew. kg	L	Z	B	F	S <sub>1</sub>	S <sub>2</sub>	Hülse	Sicherung, Quick-Lock
30.02	2.5	258	165	62	25	36	36	01.01	42.36
30.06	4.5	308	193	70	30	42	44	01.05	42.37
30.10	8.0	380	235	85	35	54	54	01.09	42.38
30.14	11.8	420	260	110	40	59	59	01.13	42.39
30.16	22.0	525	328	125	60	70	70	01.15	42.39